

Operating Instructions: 3 Position Selector Switches

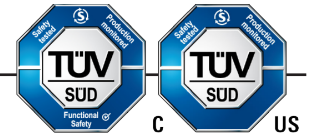

Core Elements

Description	T3A, T3D, T3E, T3F, TK7, T3H
<p>Each 3 position selector switch uses 2 output pins.</p> <ul style="list-style-type: none"> • Clockwise operation sets the lower assigned output High. • Middle position - output pins Low. • Anti-clockwise sets higher assigned output High. • Non-latching - spring return to original position. • Illumination (when selected) uses 1 input pin. • Inputs to the tGard stack are always assigned before outputs. <p>T3H -</p> <ul style="list-style-type: none"> • Inputs to the tGard stack are always assigned before outputs. • Clockwise output assigned first. • Clockwise - 40° momentary, normally open. • Anti-clockwise - 90° latching, normally closed, individually wired. 	<p>Laser Engraving Information Engraving available for 3 position selector switch is 8 characters at each switch position.</p>

Technical Specifications		T3H
Housing Materials	Painted die cast aluminium	Painted die cast aluminium
Colour	Dark Grey	Dark Grey
Ingress Protection	IP65*	IP65*
Mechanical Life	1,000,000 Operations	1,000,000 Operations
Electrical Life	1,000,000 Operations	1,000,000 Operations
LED Life	1,000,000 Operations	N/A
Ambient Temperature	-25°C to 40°C (-13°F to 104°F)	-25°C to 40°C (-13°F to 104°F)
Environment	Indoor use only	Indoor use only
Switches Conformance	IEC 60947-5-1	IEC 60947-5-1
Switching Contact Element	2 outputs	2 outputs
Switching Current	1mA MIN / 100mA MAX	1mA MIN / 100mA MAX
Switching Voltage	N/A	24V
*IP protection is to the tGard stack that this module attaches to, when correctly fitted according to installation and maintenance instructions.		

Safety Data	
Standards	EN60957-5-5 (Low-voltage switchgear and control gear).
Approvals	TÜV SÜD for Europe, Canada & USA

tGard 3 Position Selector Switch Part Number Options	
Description	Part No.
Latching (Both Sides)	T3A
Momentary	T3D
Latching (Both Sides) Illuminated	T3E
Momentary Illuminated	T3F
Key Latching (Both Sides)	TK7
Momentary / Latching	T3H

Operating Instructions: 3 Position Selector Switches

Electrical Guidance				
Part No.	Inputs	Outputs	Module operates on the safety circuits	Order of pin assignment from base to head
T3A	0	2	No	Clockwise output assigned first
T3D	0	2	No	Clockwise output assigned first
T3E	1	2	No	LED output assigned first Clockwise output assigned second Anti-clockwise output assigned Third
T3F	1	2	No	LED output assigned first Clockwise output assigned second Anti-clockwise output assigned Third
TK7	0	2	No	Clockwise output assigned first
T3H	1	2	No	Clockwise output assigned first Clockwise - 40° momentary, normally open Anti-clockwise - 90° latching, normally closed, individually wired

Figure 1: Wiring Diagram

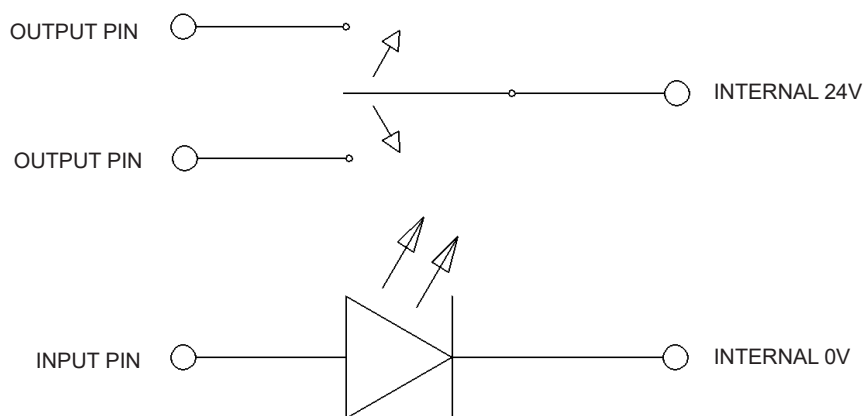
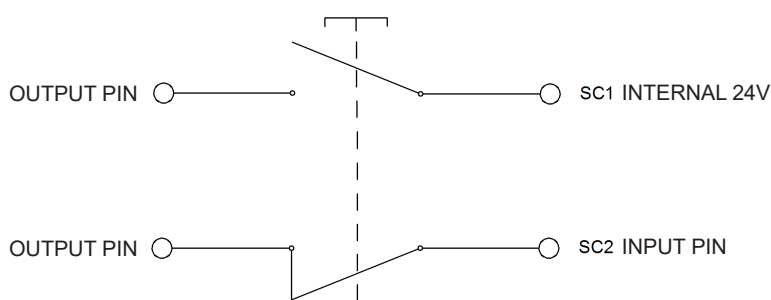

Figure 2: Wiring Diagram - T3H



Operating Instructions: 3 Position Selector Switches

Figure 3: Dimensional Drawing - T3A, T3D, T3E, T3F & T3H

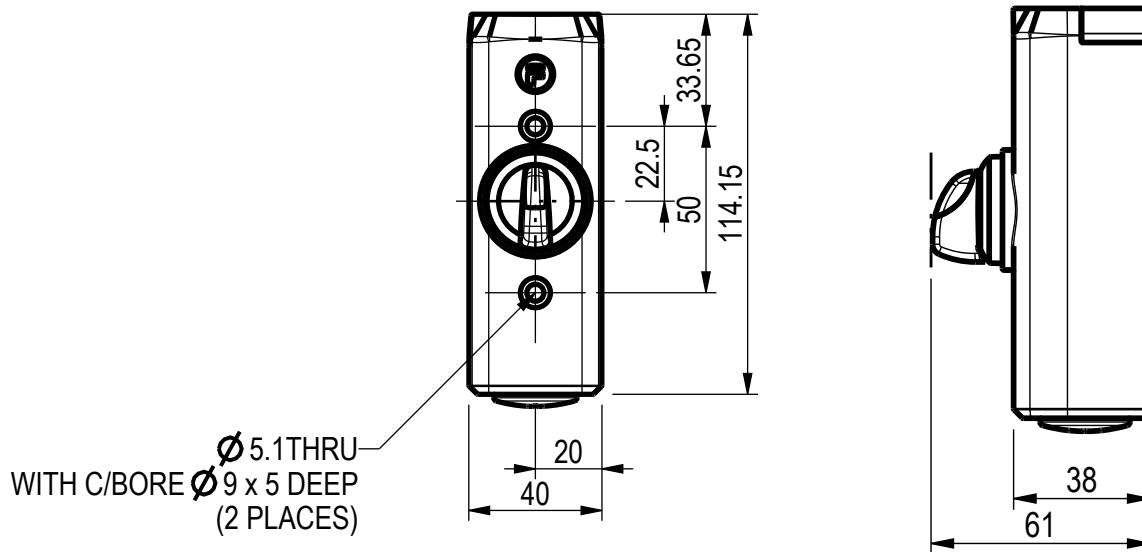

Figure 4: Dimensional Drawing - TK7

