



WIRELESS

Safety Communication
SIL 3, PlE, Cat. 4

SAFETY SIMPLIFIER

Wireless Safety Systems
Decentralized Safety PLC

handling award 2017



SSP

Safety System Products

Safety solutions from a single source

Years of experience, innovative developments, concentrated know-how in the area of machine safety



The System - Safety Simplifier

Design of safety solutions for stationary or mobile machines and plants has never been as simple as it is today. With the patent-pending Safety Simplifier we provide you with a wireless, flexible safety technology as a plug & play solution!

- modular design
- safe wireless or CAN network
- programmable safety PLC
- 14 safe I/O's
- 2 safe relay outputs
- networking of up to 16 units
- two-way communication
- networking of up to 256 I/O's

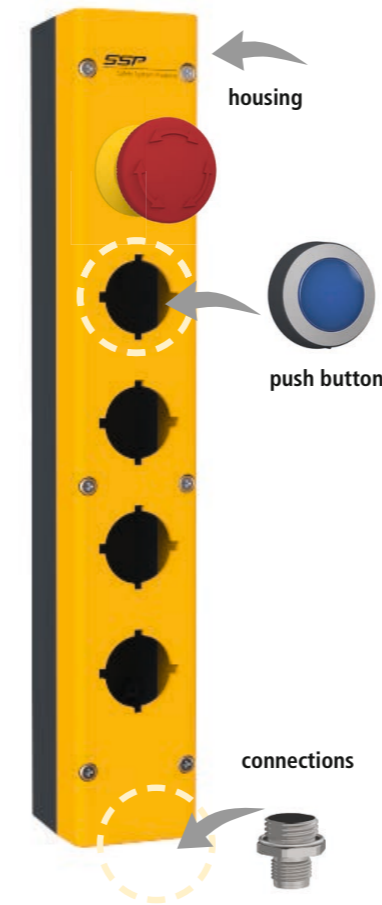

Configuration Tool

Configure your individual Safety Simplifier on our website!
www.safety-products.de

Products and Systems

With the Safety Simplifier we provide safety exactly where it is needed and help you to create user-friendly safety systems, such as at the access doors. Just connect your sensors, guard lockings and light curtains. Select the pushbuttons and/or the emergency stop buttons and you will receive a complete safety solution with evaluation and diagnosis. This data will be safely forwarded to your existing plant either directly or using another Safety Simplifier.

we simplify safety

PLUG AND PLAY - Safety Devices

Safe I/O's for connection of safety devices



up to 5 control elements

IP 65

Exchangeable button elements

Individual labelling

LED diagnosis using the touchpad



WIRELESS

Safety Communication
SIL 3, Ple, cat 4

40 mm construction width for installation on aluminum profiles

Spring terminals secure the connections also in case of strong vibrations

14 I/O's as safety inputs or redundant OSSD outputs

4 relays for 2 × double-safety outputs (optional)

Memory card with application software for easy exchange

Wireless interface for - safe communication - programming and diagnosis

USB port

Safe CAN connector (optional)

PLUG AND PLAY - Machines

Safe I/O's for the plant control



Select from a large number of housings, button spaces with or without LED display.



In order to allow more options, you can put the housings together. The IP65 protection class is still retained thanks to the sealing.

Decide which button arrangement is best for your application.

For our customers and their applications we developed four different hardware versions of the Safety Simplifier.

Hardware version	Number of digital safe I/O's	Number of safe relay outputs	Safe wireless communication	Safe CAN communication
S14LDRB	14		YES	
S16LDRB	14	2	YES	
S14LDRBCA	14		YES	YES
S16LDRBCA	14	2	YES	YES

Thanks to its modular design, Safety Simplifier can be subsequently expanded, also in systems that are not equipped with a CAN connection. The standard built-in wireless module can be easily activated or deactivated with the free Simplifier Manager.

However, the Safety Simplifier is not just a decentralized Safety PLC. In addition, the system integrates control devices, such as emergency stop buttons, illuminated buttons for various functions or key switches for activation of different operating modes.

Additional safety components such as RFID sensors, safety guard lockings, light curtains, safety edges and many others safety components can be connected and integrated by means of the four connection possibilities on the upper and bottom surface.

Safe Communication

The right solution for each application – Wireless or CAN network



State-of-the-art safety technology

In the factory as well as in the process automation, a trend for increasingly complex, decentralized applications has become apparent. One of the big challenges in the safety field is the most efficient possible coupling of various safety components. For this purpose SSP provides with the Safety Simplifier simple and flexible solutions: The safe coupling via wireless or safe CAN connection. Regardless which solution you choose, in the maximum configuration up to 16 participants with up to 256 inputs and/or outputs can be securely networked together.

I/O assignment of the Safety Simplifier S16

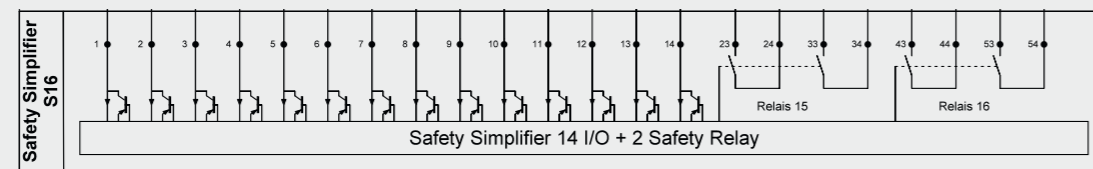

Safe CAN network

Network up to 16 Safety Simplifier via safe CAN communication. Every single Safety Simplifier in the system can get all available safety information from other participants. The cable length of up to 250 m enables the application in large plants with longer distances.

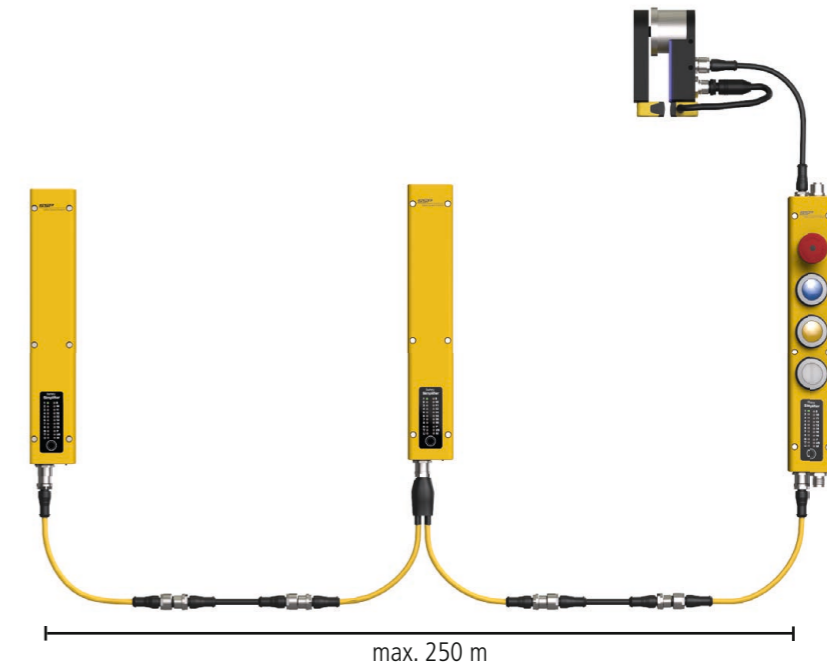

Safe wireless network & repeater function

Network up to 16 Safety Simplifier via safe wireless communication. Thanks to the standard implemented repeater function you will achieve an optimum process safety. Each Safety Simplifier shares all available safety information with all other Safety Simplifiers within its range. Two modules communicate with each other over a distance of up to 100 m. For longer distances or under unfavorable ambient conditions additional Safety Simplifier can be applied as repeater.

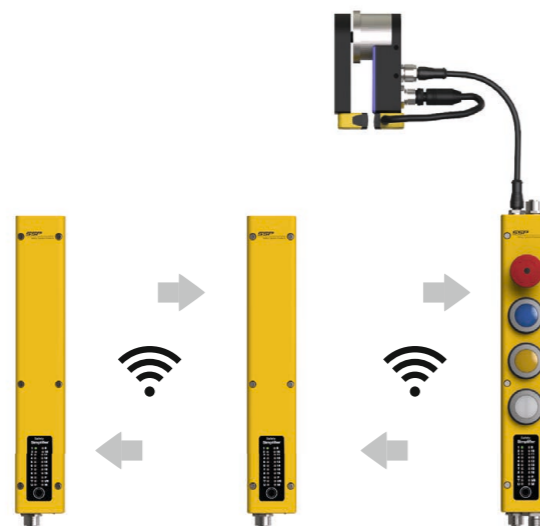

Safe combined networking of wireless and CAN

Combine flexibly the safe wireless and CAN network and reduce your wiring and commissioning effort. The advantages of each single communication type are available as combined network, everywhere where a process-safe wireless connection is not possible, you can connect the Safety Simplifier via CAN wire. In a system of 16 Safety Simplifiers you can freely select which units communicate via CAN or wireless connection.

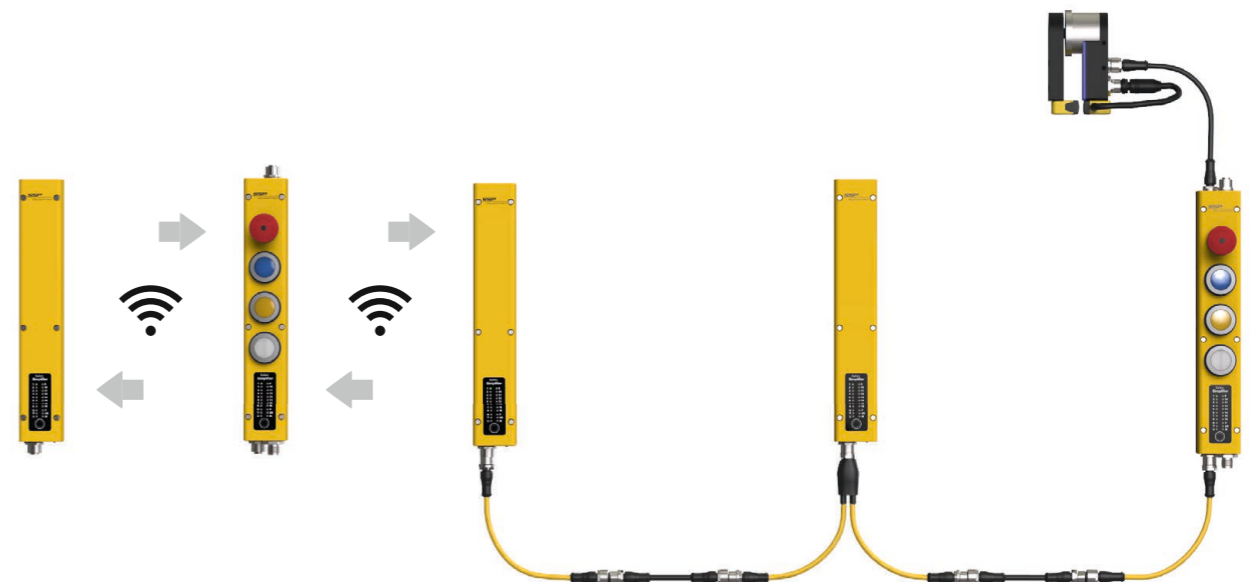

Robot Cell implementation with Safety Simplifier

Various application areas of the Safety Simplifier



Safety Simplifier on the control cabinet of a processing machine: Thanks to the integrated safety PLC, all safety functions of the processing machine can be applied or the Safety Simplifier acts as an interface between the individual components.



The Safety Simplifier installed on the tool stand monitors the safe tool change of the robot.



Operational unit and monitoring of the safety switch (e.g. tGard) on the sliding door.

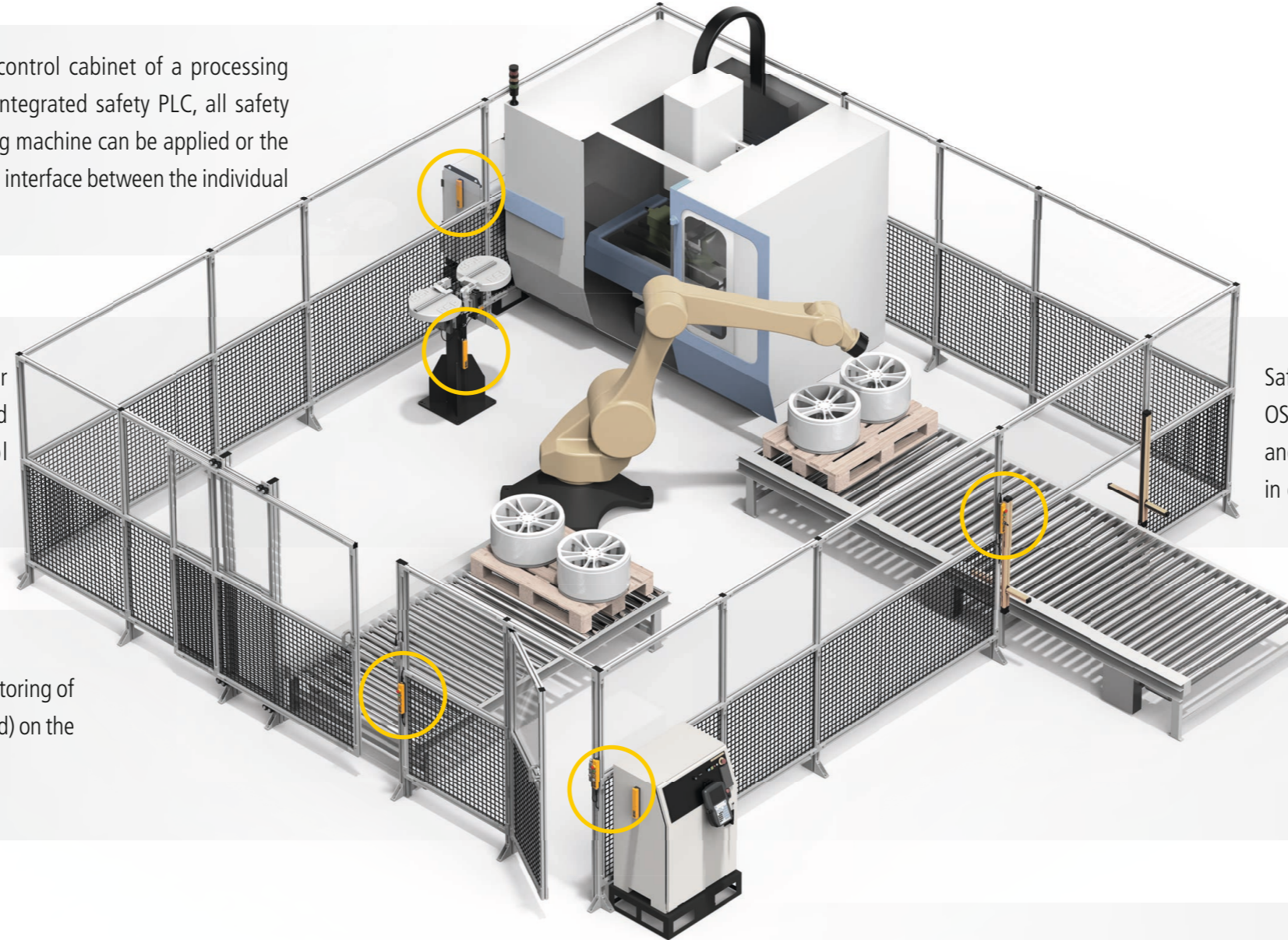

Reduction of commissioning time

Thanks to the IP65 protection class of the Safety Simplifier, an external safety PLC or even a control cabinet for the safety technology are no longer necessary for your robot cell. The wiring effort of the safety components is reduced to a minimum using the safe wireless communication.



Safety Simplifier evaluates the OSSD signals of the muting light grid and provides the override function in case of faults.



The Safety Simplifier installed on the control cabinet of the robot for safe communication and shutdown of the robot.

Easy planning

Thanks to the modular design, up to 16 Safety Simplifier can be decentrally distributed on your robot cell and perform all safe and unsafe control tasks, where necessary. If additional doors, robots or machines are subsequently integrated, they can be easily equipped with the Safety Simplifier and connected to the safety circuit.



Operational unit and monitoring of the safety switch on the wing door.

Robot Cell Implementation - Safety Simplifier

With safe wireless communication

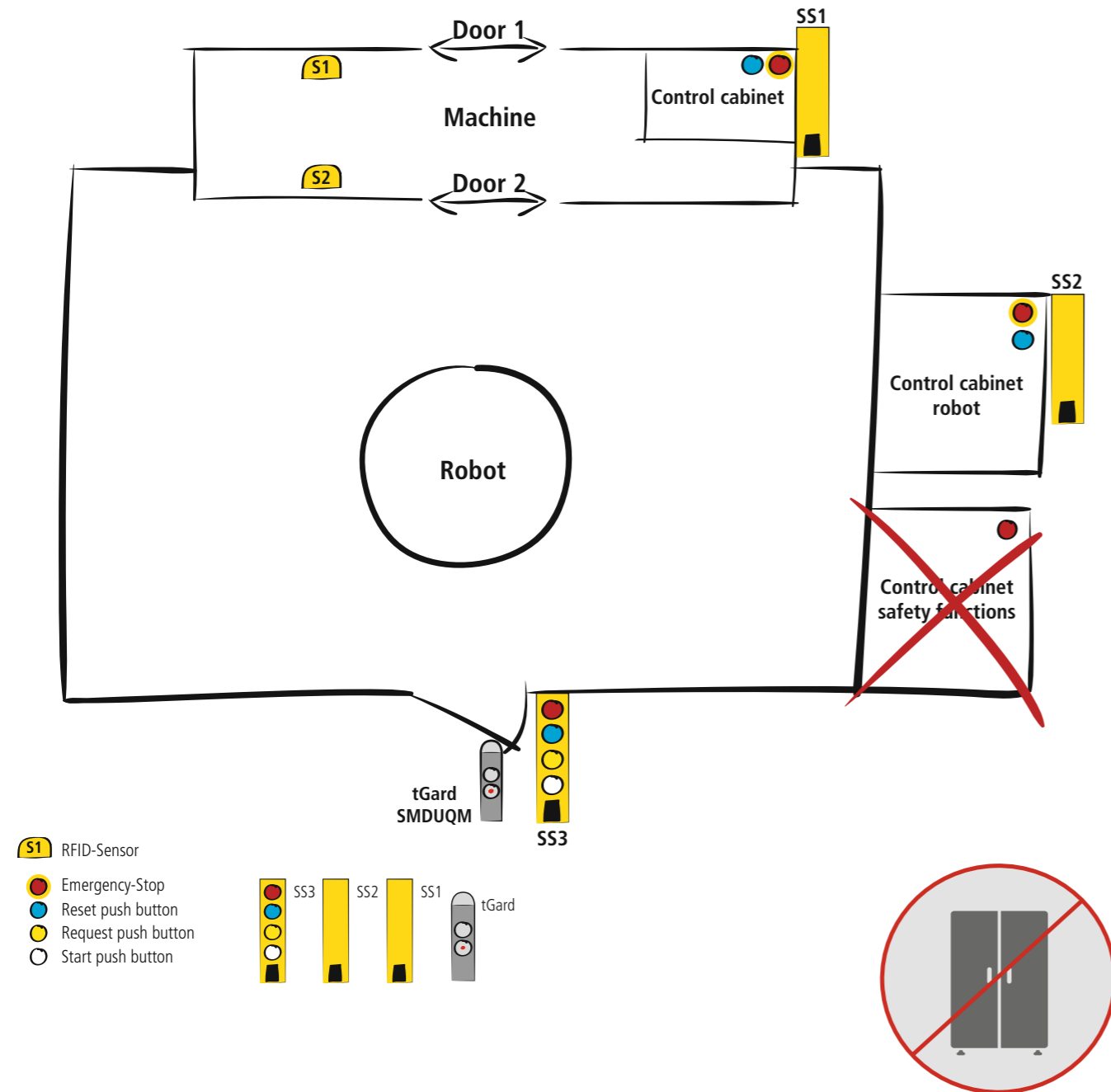

Application description

The following drawing shows a processing machine automated with a handling robot. For the implementation of the safety technology, only three decentralized Safety Simplifier are necessary for the evaluation of all safety functions. Consequently, a safety PLC and the otherwise mandatory control cabinet are no longer necessary. Your planning effort simplifies, the plants can be standardized and expanded in a modular manner. Additional robots or doors that are required, will be quickly connected thanks to further Safety Simplifier. Using the clear system and software design, the validation of hardware and software will be quickly and comfortably implemented.

Processing machine requirements

Requirements of the machine

A standard processing machine with safety technology (door 1 and door 2 + internal emergency stop, speed monitoring etc.) that is already internally connected (e.g. safety PLC) usually requires for external connection following interfaces:

Processing machine interface

Inputs	Outputs
2 × potential-free for emergency stop	1 × emergency stop on the robot
2 × potential-free for door circuit	2 × potential-free relay outputs
1 × input door circuit requirement	1 × machine door circuit open on the robot
1 × input reset (optional)	2 × potential-free relay outputs
	1 × machine in basic position
	1 × info door 2 open/closed on the robot

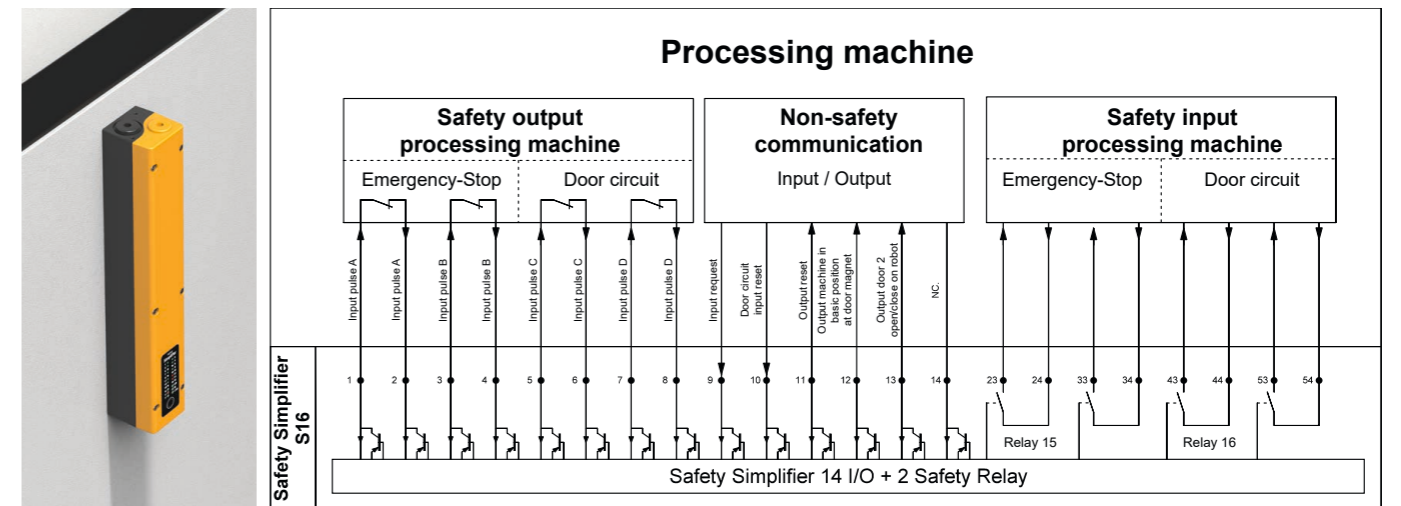

Denomination	Item	Item number
S16LDRB-H10-Q1A-Q2A-Q3A-Q4A	Safety Simplifier	SP-X-89-000-03

Industrial robot requirements

An state-of-the-art industrial robot requires for the integration in a cell following interfaces for the safety technology (e.g. Safety PLC)

Robot control cabinet

Inputs	Outputs
2 × potential-free for emergency stop	2 × emergency stop on the processing machine
2 × potential-free for door circuit/operator protection	2 × potential-free
1 × input door circuit requirement (move the robot to the basic position)	1 × robot in basic position, info to the door magnet
1 × input reset (optional)	1 × robot retracted into the processing machine/robot outside of the processing machine
1 × input reset (optional)	
1 × input door 2 open/closed processing machine	

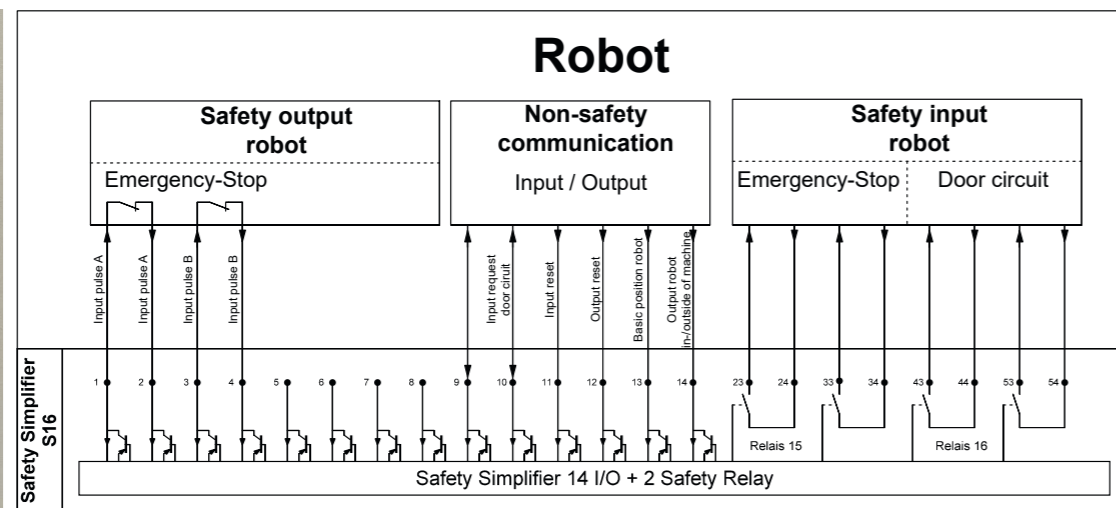

Denomination	Item	Item number
S16LDRB-H10-Q1A-Q2A-Q3A-Q4A	Safety Simplifier	SP-X-89-000-03

Requirements safety switch protective enclosure

In order to protect the robot cell, a safety switch with a minimum performance level PLd acc. to EN ISO 13849-1 is required. In case that the robot cell has a complex design, the safety switch must be additionally equipped with an escape release.

The safety switch tGard selected in the example meets the above mentioned requirements and can be optionally extended with an escape release. The M12 12-pin male connector makes it easy to connect with the Safety Simplifier.

Safety switch with guard locking (PLd) at the service door

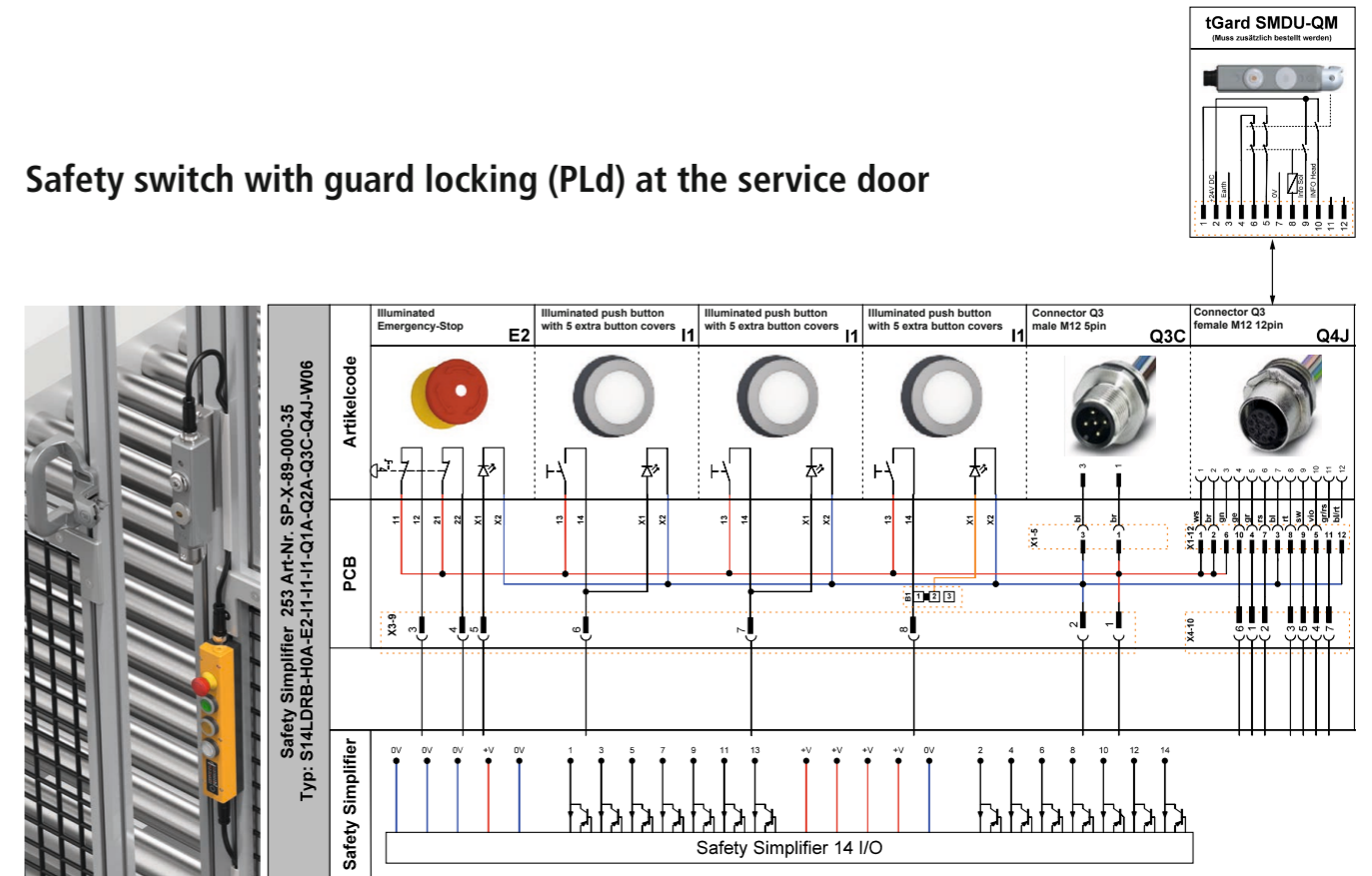

Denomination	Item	Item number
S14LDRB-H0A-E2-I1-I1-Q1A-Q2A-Q3C-Q4J-W16	Safety Simplifier	SP-X-89-000-56
THM-SMDU-QM	t-Gard safety switch	ITM-00159181

An immense saving of time

Estimated effort for wiring

Control cabinet (omitted)	-
Service door safety switch to Safety Simplifier	5 minutes
Safety Simplifier S1 installation and wiring to the processing machine	30 minutes
Safety Simplifier S2 installation and wiring to the robot	30 minutes
Safety Simplifier S3 voltage supply cable routing	30 minutes
Overall effort for wiring and cable routing	95 minutes

Simplifier Manager Configuration Software

Diagnosis and programming - easier than ever!

Simplifier Manager is the free software for the Safety Simplifier System

Program the safety functions in an easy and uncomplicated way using the Simplifier Manager configuration software. The functional modules for emergency stops, safety switches, light curtains, two-hand controls, mode selector switches and many others are available as standard.

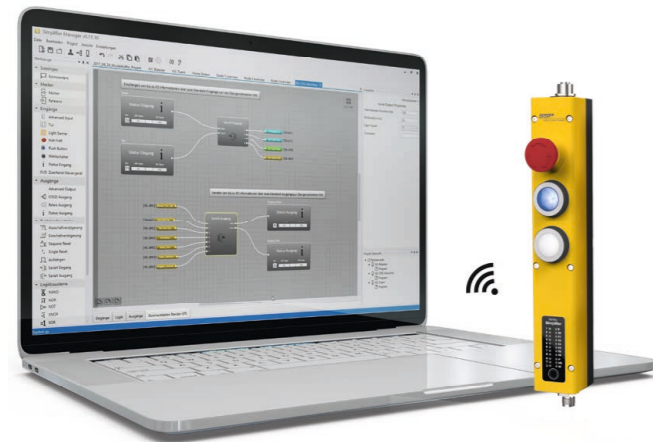

- saves time and resources
- drag & drop function
- user-friendly, intuitive interface
- predefined functional modules for easy and fast programming
- wireless connection using the SRM stick or optionally via USB connection
- on-line mode for live diagnosis

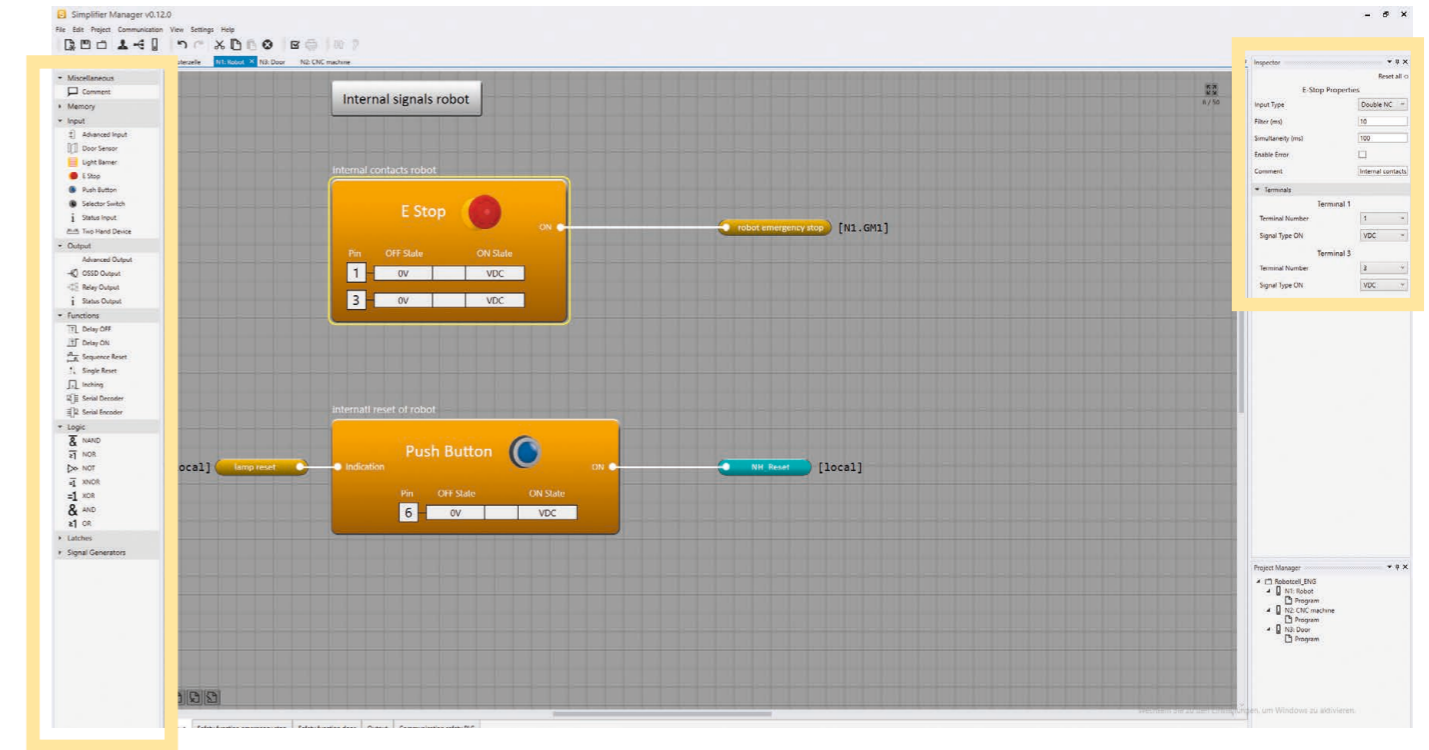

Functional modules

Predefined functional modules as well as the drag & drop functionalities reduce the programming time and simplify the design of your application.

Examples of functional modules:

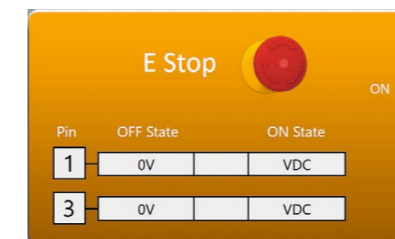

emergency stop module



button module

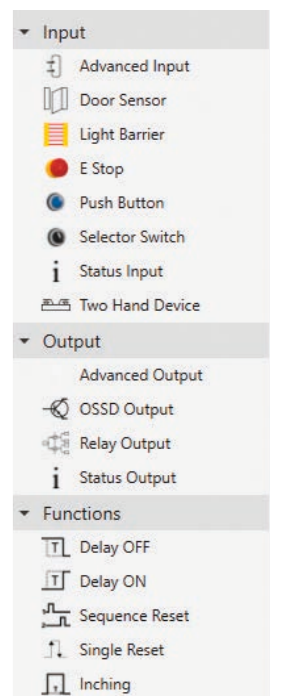

Simplifier Manager software user interface

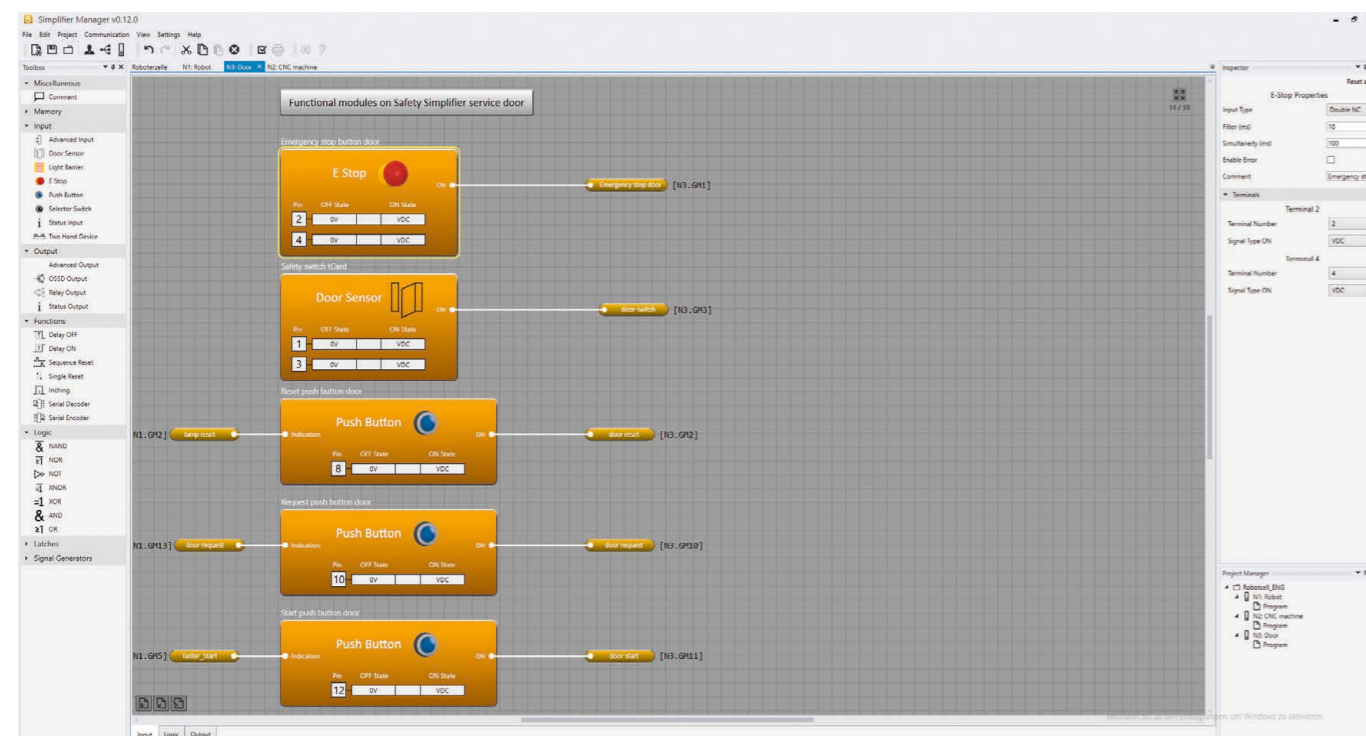

Configuration of the functional modules

The properties of the individual functional modules can be configured with the inspector window. Examples of parameters:

- one- or two-channel monitoring
- filter times
- simultaneous times
- fault output activation
- application of clock signals for cross-circuit detection

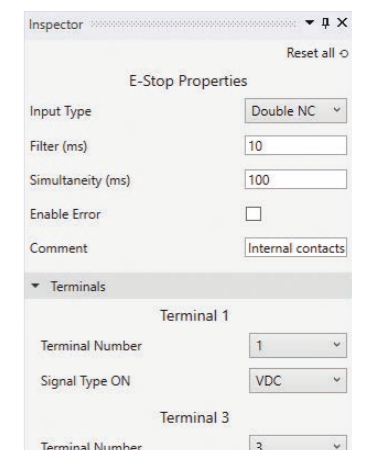

Software validation with clear program design

Comment function

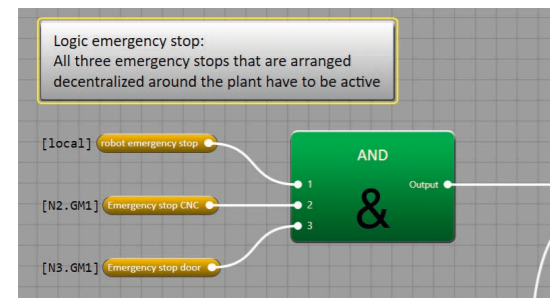
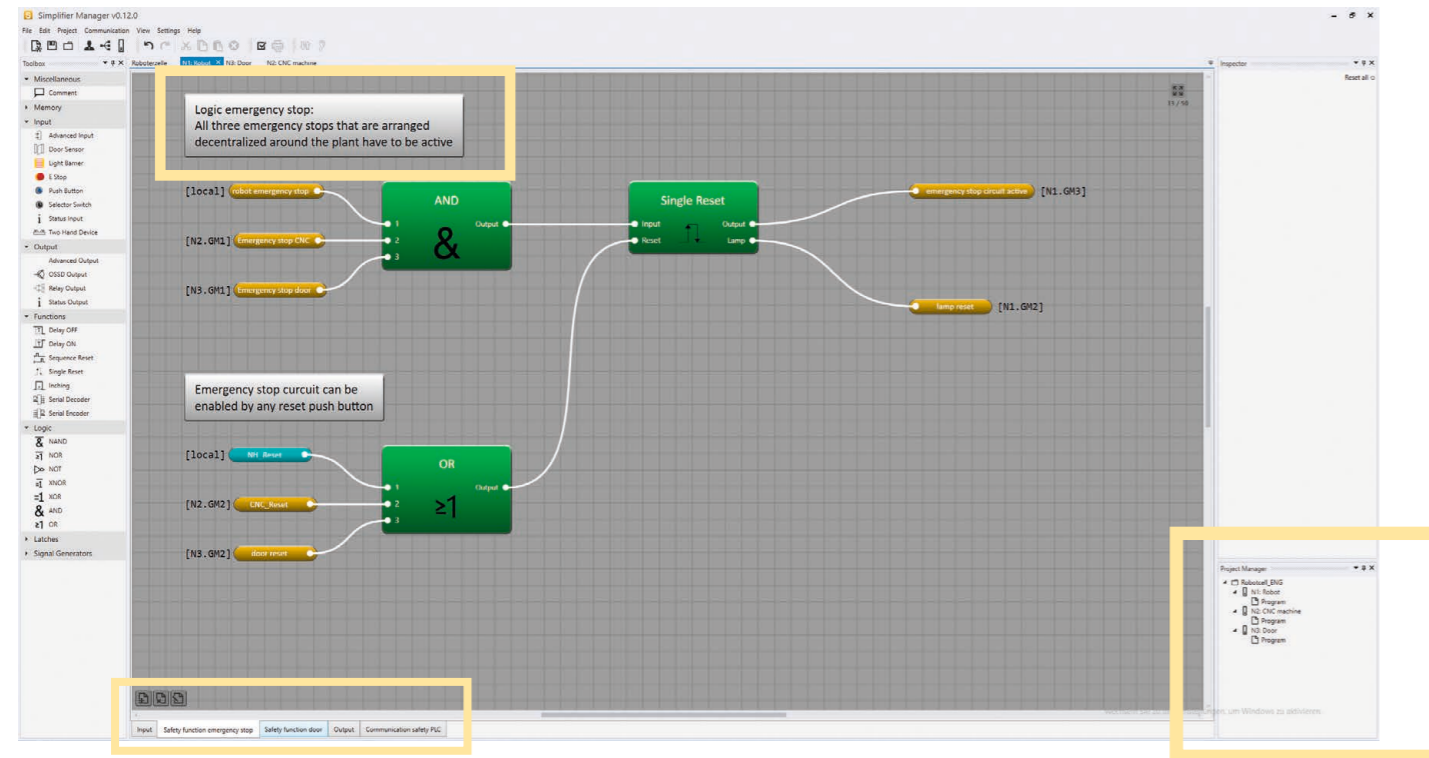

Add your comments where necessary to make the program code easier to read and to explain the functions. Thus, the future users can simple and easy understand the programming and extend it, if necessary.

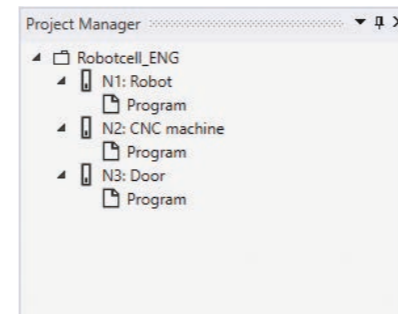

Clear presentation of the program structure

Simplifier Manager is clearly structured and allows you quick access to the individual programs of the participants.

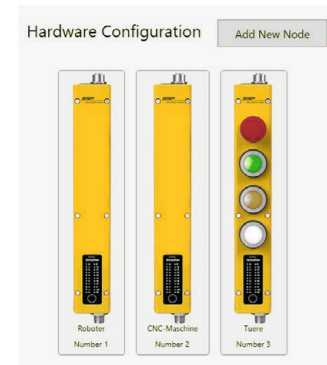

Distribution of safety functions

In order to gain more clarity, the safety functions can be arranged on different pages using memories. This simplifies the validation and programming of your application.

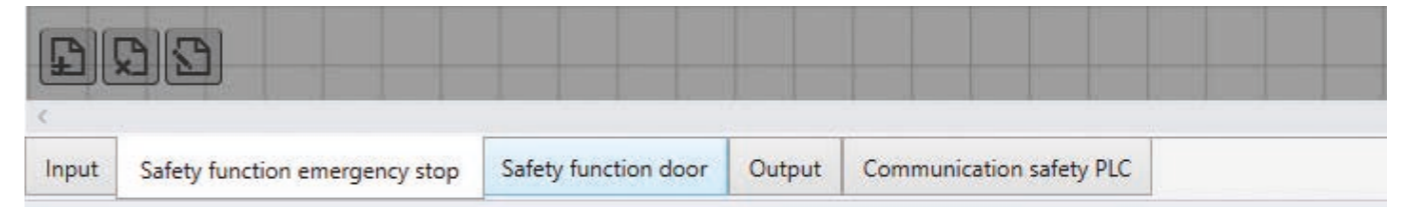
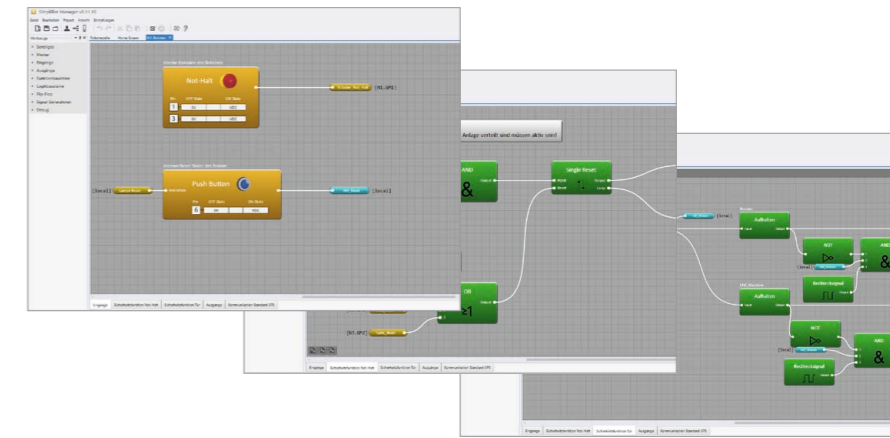

Validation and check of your application software

The Safety Simplifier Manager supports you during creation of the validation documentation according to EN ISO 13849-2. The check report contains all safety-related parameters like PFHD values, Diagnostic Coverage (DC) and Performance Level (PL) according to EN ISO 13849-1 for the Safety Simplifier System.

Project report

Automatically generate the project report using the Simplifier Manager. All safety-related parameter are clearly listed and presented.

Project Report

Generated with Safety Simplifier Manager version 0.11.10

Project Name: Roboterzelle
Responsible person: Nathanael

Date: 20.10.2017, Time: 10:08
Project checksum: B3323619
Description:

Nodes in system: 3
Radio frame time: 6,375 ms
CAN frame time: 3,0625 ms

Radio and CAN Timeouts
Short Timeout Actual: 19,125 milliseconds (3 frames)
Long Timeout Actual: 76,5 milliseconds (12 frames)
Expected average radio reaction time (stochastic): 12,75 milliseconds
Expected average CAN reaction time (stochastic): 3,0625 milliseconds
Warning: expected radio and CAN reaction times depend on communication quality and installation.



Online Mode - Diagnosis Function

With the SRM stick (Simplifier Radio Monitor stick) You have the possibility to access the online mode and therefore to start the integrated diagnostic function either wireless or via USB interface.

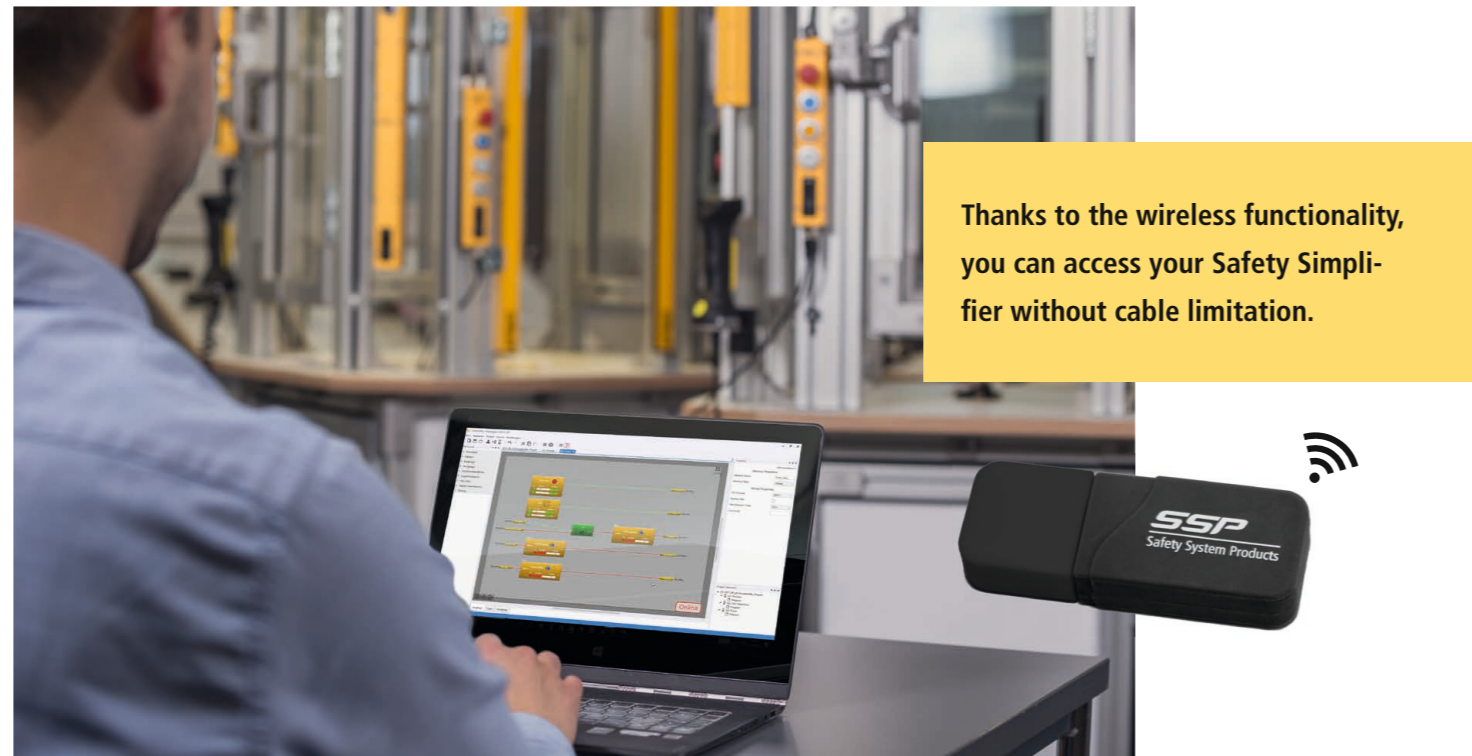

The unique online mode via wireless interface makes programming much easier and considerably reduces the commissioning time.

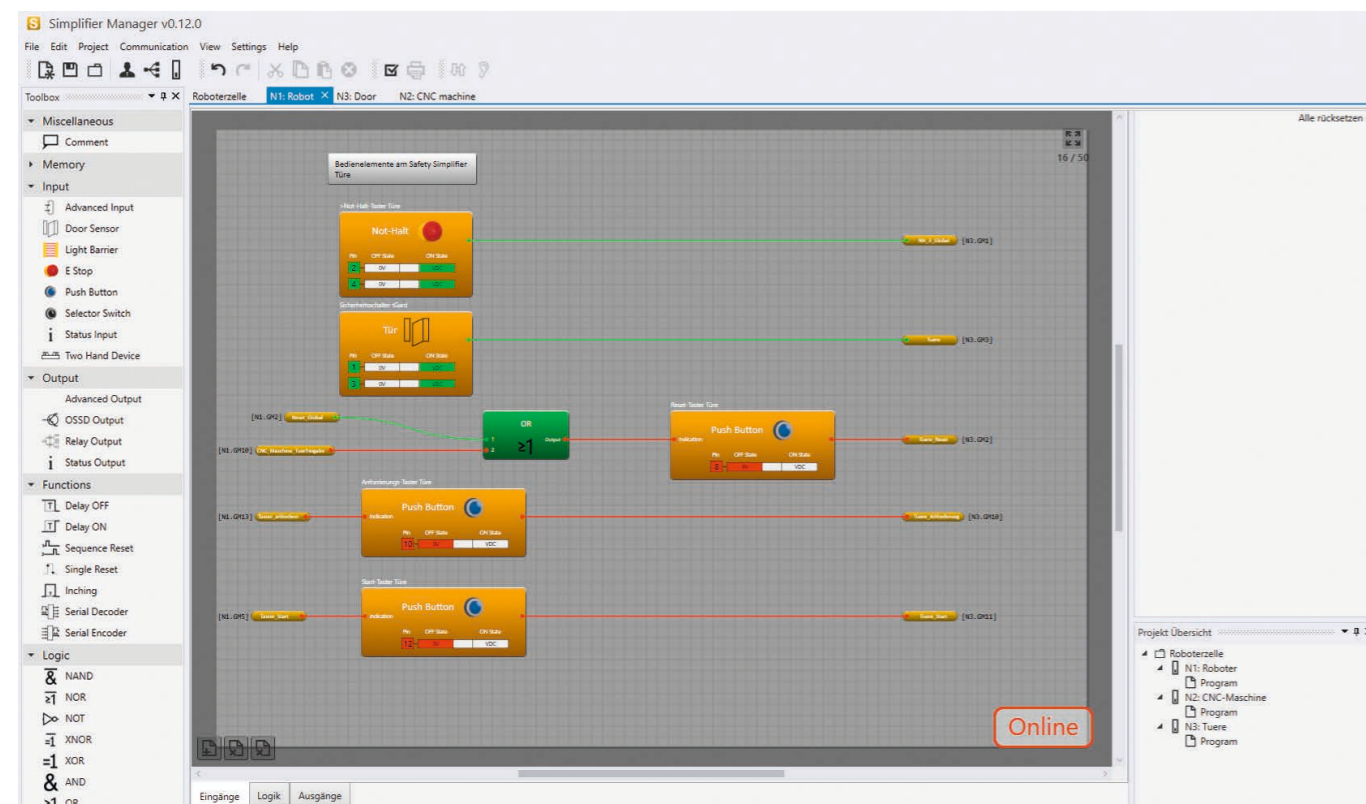

Simplified overview of the online mode

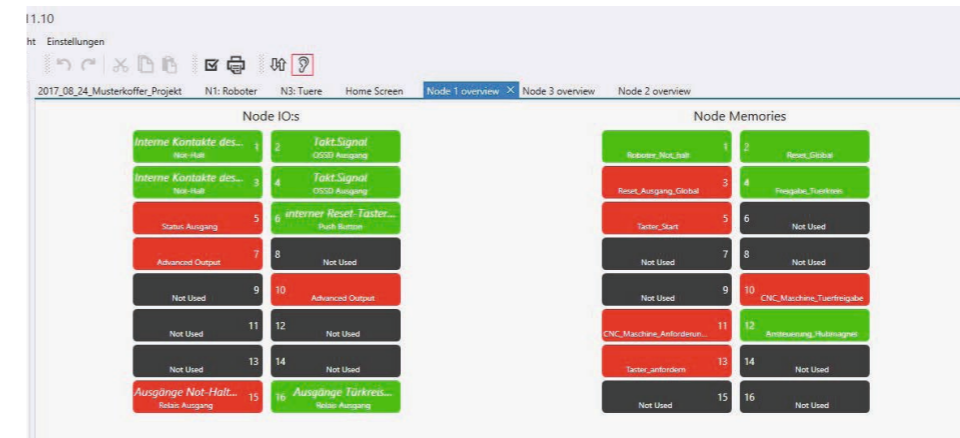

The simplified overview in online mode provides you with a quick overview of your system.

Green = output or input activated

Red = output or input not activated

Gray = not used in program

Programming and upload of the application software

Program your application software with the Simplifier Manager. Install the application software for all participants using the SRM stick (Simplifier Radio Monitor Stick). A cable connection to the Safety Simplifier is not necessary.

In the case that you don't have the SRM stick at hand, you can also use all functions via standard micro USB cable.

All safety-related data like serial numbers of the devices, check sums, network ID, wireless channel and quality are displayed.

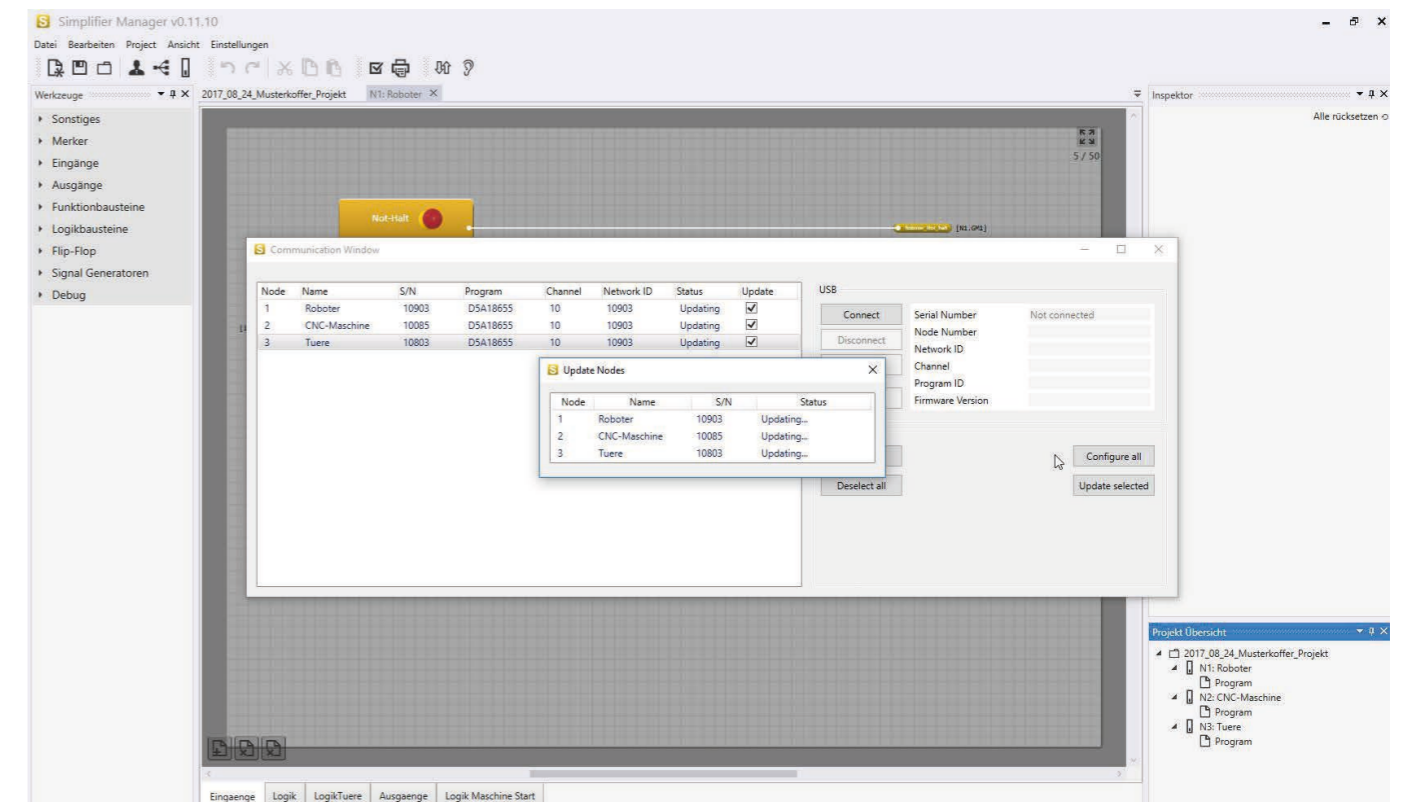

Communication with the standard PLC

Free of charge and in an easy and effective way the Safety Simplifier provides bidirectionally all information to the higher-level standard PLC. Reprogram two of 14 inputs and/or outputs as serial outputs. Use our standard modules in the Simplifier Manager. These modules send through two outputs up to 32 pieces of information to their higher-level control unit. If these pieces of information are not sufficient, further free I/O's can be used for communication without limitation.

Free of charge functional modules for Siemens and Beckhoff are available on our homepage.

www.safety-products.de



Innovation!
Reduction of
inputs and outputs
of 50%

Innovative illuminated buttons reduce inputs and outputs

Our motto „we simplify safety“ is also reflected in easy functionalities such as our illuminated buttons.

Standard market control units require an input and an output for the evaluation of illuminated buttons. Using the Safety Simplifier, you will reduce the number of inputs and outputs by 50% because one illuminated button can be connected to just one connecting pin.

Consequently, the input and output function can be used at the same time. On a standard door with the functions: Emergency stop button, illuminated reset button, illuminated requirement button and illuminated start button consequently three inputs or outputs can be saved.

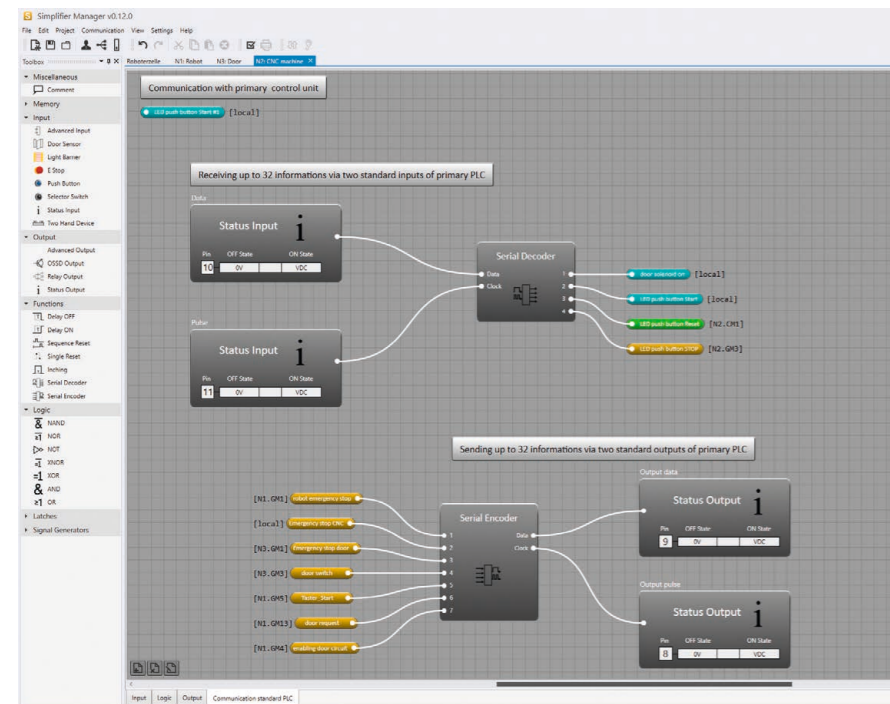

Communication with the Siemens PLC from the Simplifier Manager

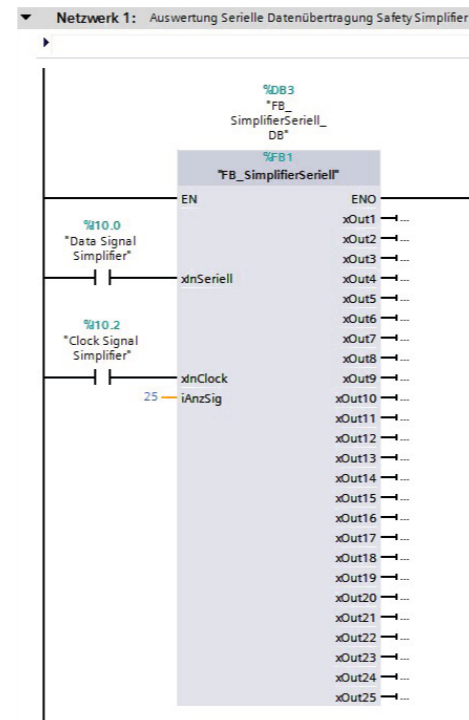

Functional module for Siemens PLC

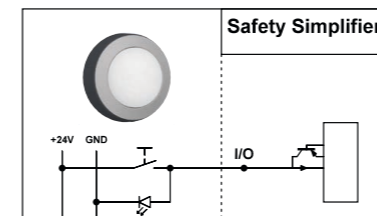

Electrical wiring of illuminated buttons

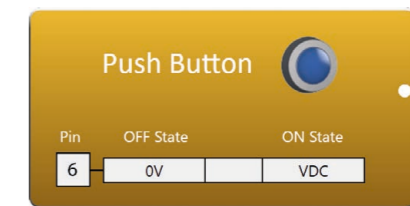

Innovative functional module for illuminated buttons

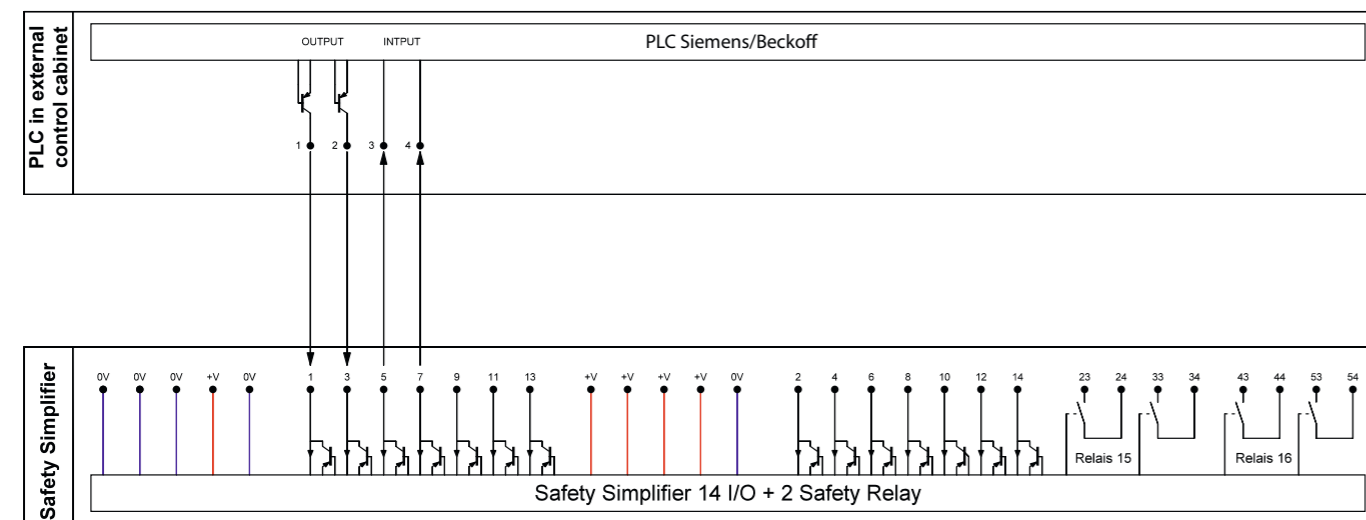
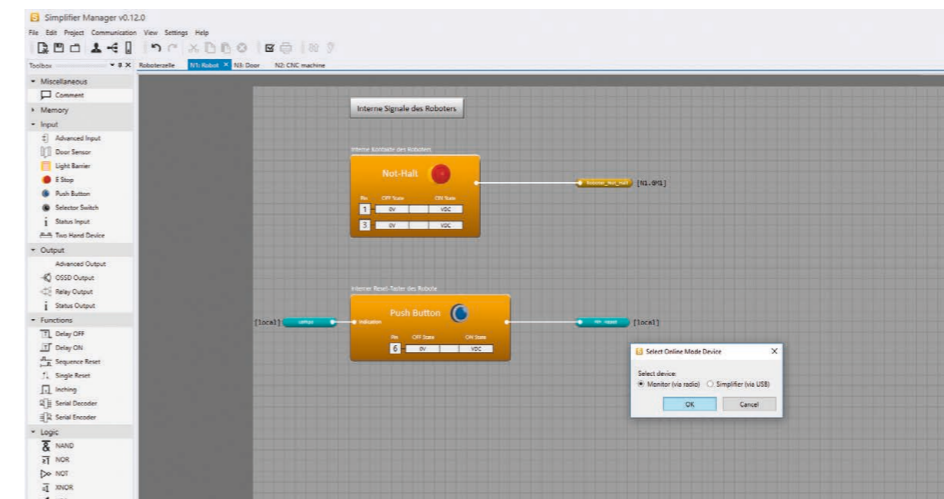

Simplifier LED and software information

The LED display of the Safety Simplifier always displays the status of its own inputs as well as the status of further Safety Simplifier in the system. For that, select the view using a touch sensor on the panel.

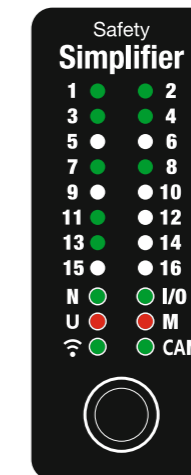

Application Examples

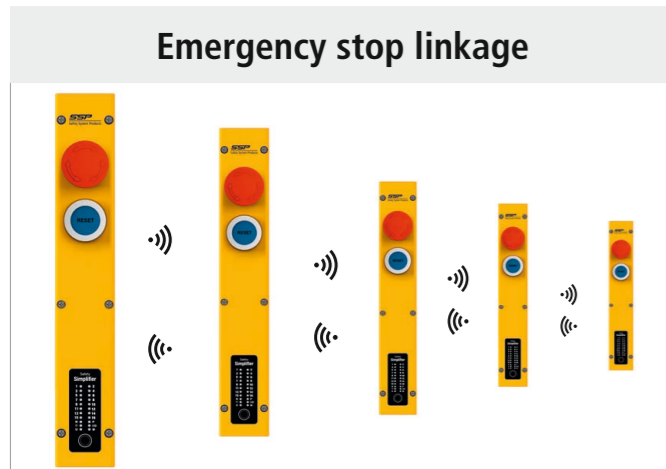

Linkage of an emergency stop circuit either wireless or via double relay output of the Safety Simplifier.



Reduction of wiring effort, easy integration of safety functions that are difficult to access.



Thanks to the wireless interface, the vehicles can be switched off safely with an external emergency stop button.

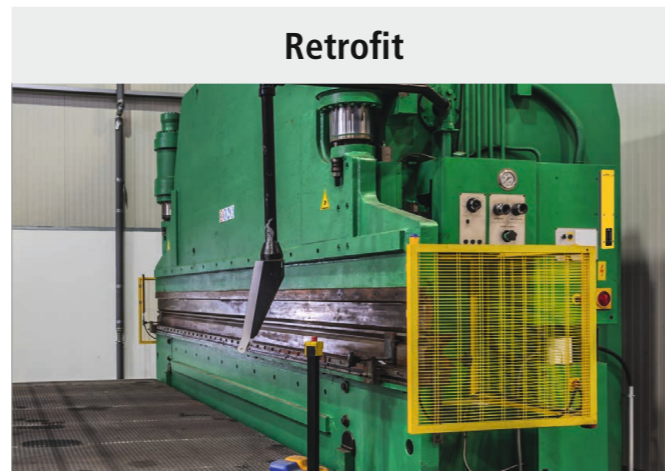

Fast and cable-saving retrofit of old plants, that can be implemented in stages and extended if required.



As a stand-alone version with 16 safe I/O's, the Safety Simplifier monitors the emergency stop buttons, two-hand controls, light curtains and safety valves.



It takes over the functions for requirement, reset button and emergency stop functions. Safety times prevent from premature opening of the door in case of danger.

Customer Application Concept

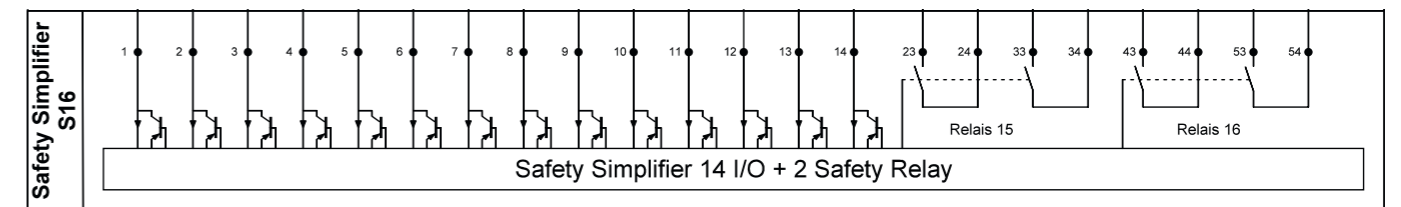



Safety System Products

SSP Safety System Products GmbH & Co. KG

Max-Planck-Straße 21 · 78549 Spaichingen

Tel. +49 7424 98049-0 · Fax +49 7424 98049-99

www.safety-products.de · [info@ssp.de.com](mailto:info@ssp.de)

Our partners

SWEDEN

Safety System Products North AB

S-439 31 Onsala

info@sspnorth.se · www.sspnorth.se

AUSTRIA

contra GmbH

A-1210 Wien

office@contra.at · www.contra.at

SPAIN

EUROTECH systems

STA. COLOMA DE CERVELLO

info@eurotechsys.com · www.eurotechsys.com

ITALY

MASAUTOMAZIONE S.R.L.

IT-20090 Segrate

info@masautomazione.it · www.masautomazione.it

CZECH REPUBLIC

CONTRA spol. s r.o.

CZ-664 51 Brno-Šlapanice

contra-brno@contra-brno.cz · www.contra-brno.cz

POLAND

CONTRA SP. z o.o.

PL-43 - 400 Cieszyn

office@contra-polska.pl · www.contra-polska.pl

we simplify safety