



SERIE 22

MINIATURE BLIND HOLLOW SHAFT INCREMENTAL ENCODER FOR INDUSTRIAL APPLICATIONS

- Resolution up to 10.000 pulses per turn
- External diameter 36,5 mm
- Blind hollow shaft \varnothing 6 mm
- Shaft fixing through setscrew
- Protection class IP64 according to DIN EN 60529
- Anti-rotation system through flexible flange or pin torque support
- Connection by cable (other cable length available) or industrial connector M12



Optical Encoder Incremental Encoder Miniature Encoder Vibration and shock resistant IP64 Temperature range Express Delivery

Setscrew / Anti-rotation pin (93.0108204)

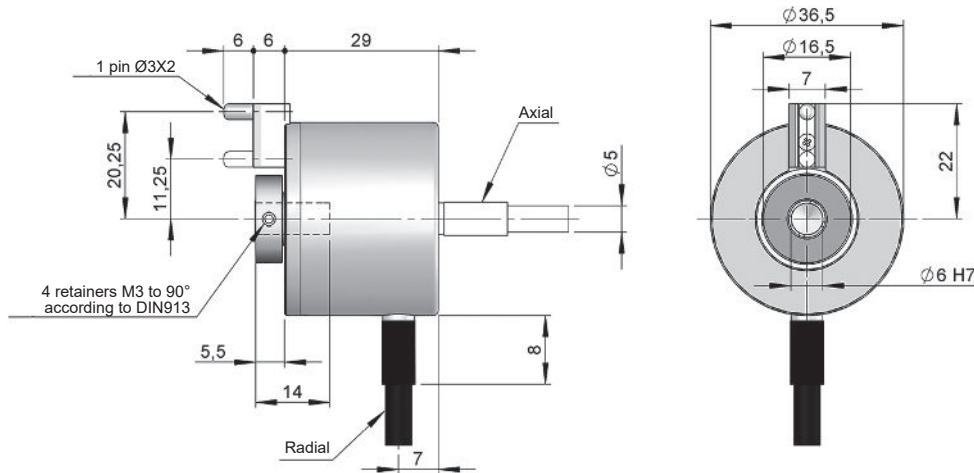

Drawing connection type 1/2, anti-rotation system type 2 (pin included)

Setscrew / Flexible flange (90.1037)

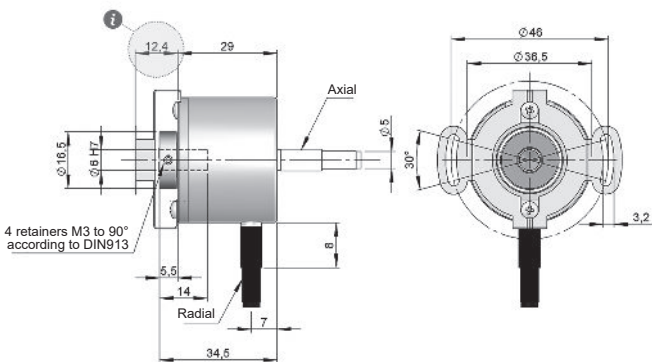

Drawing connection type 1/2, anti-rotation system type 1

Setscrew / Flexible flange (90.1111)

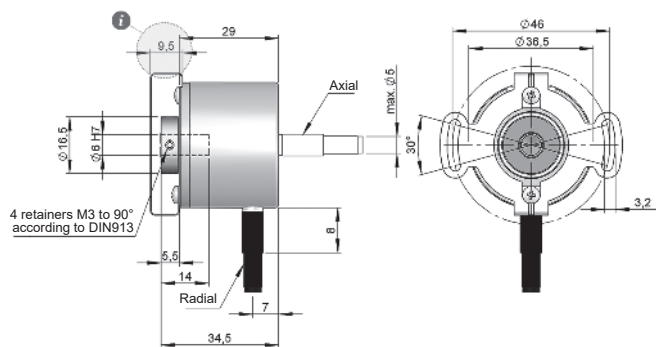

Drawing connection type 1/2, anti-rotation system type 3



SERIE 22

MINIATURE BLIND HOLLOW SHAFT INCREMENTAL ENCODER FOR INDUSTRIAL APPLICATIONS

REFERENCE							Reference example: 22-1721-500
Serie	Anti-rotation system	Output signals	Connection	Power Supply / Electronic output	Pulses number	Special customer	
22 -	<input type="checkbox"/>	<input type="checkbox"/>	<input type="checkbox"/>	<input type="checkbox"/> -	<input type="checkbox"/> <input type="checkbox"/> <input type="checkbox"/> <input type="checkbox"/> <input type="checkbox"/>	<input type="checkbox"/> <input type="checkbox"/> <input type="checkbox"/> <input type="checkbox"/>	
	1. Flexible flange (90.1037) 2. Anti-rotation pin (93.0108204) 3. Flexible flange (90.1111) (*)	2. A+B 3. A+B+0 7. A \tilde{A} +B \tilde{B} +0 $\tilde{0}$ 8. A \tilde{A} +B \tilde{B}	1. Axial cable 2. Radial cable 3. Radial M12 8p CCW	0. 11...30 VDC / NPN Open collector 11...30 VDC 1. 11...30 VDC / Line driver differential Push-Pull 11...30 VDC 2. 5 VDC / RS422 5 VDC (compatible TTL)		PT00. -40°C Order your reference Step file 3D info@encoderhohner.com <i>service available in 24 h</i>	

(*) Anti-rotation system type 1 (Flexible flange 90.1037), 2 (Anti-rotation pin 93.0108204) and 3 (Flexible flange 90.1111) supplied assembled.

MECHANICAL SPECIFICATIONS	
Materials	Cover: Aluminium Housing: Aluminium Shaft: Brass
Bearings	Ballraces
Bearings lifetime	1x10 ¹⁰ rev.
Housing fixing	Anti-rotation pin or flexible flange (included)
Permitted misalignment	±0.3 mm axial, ±0.1 mm radial (93.0108204) ±0.3 mm axial, ±0.2 mm radial (90.1037) ±0.2 mm axial, ±0.1 mm radial (90.1111)
Shaft fixing	Setscrew
Blind hollow shaft diameter	6 mm
Maximum number of revolutions permitted mechanically	6000 rpm
Protection against dust and splashes according to DIN EN 60529	IP64
Rotor inertia moment	10 gcm ²
Starting torque at 20°C (68°F)	≤ 0,01 Nm
Maximum load permitted on axial shaft	20 N
Maximum load permitted on radial shaft	40 N
Weight aprox.	0,1 Kg
Operating temperature range	-20°C to +80°C - Standard -40°C to +80°C - Special Customer PT00
Vibration according to DIN EN 60068-2-6	100 m/s ² (10Hz...2000Hz)
Shock according to DIN EN 60068-2-27	1000 m/s ² (6ms)
Maximum pulses per turn	10.000
Axial or radial connection	2 meters cable or industrial connector M12 (other cable lengths available on order) Female connector not included

SERIE 22

MINIATURE BLIND HOLLOW SHAFT INCREMENTAL ENCODER FOR INDUSTRIAL APPLICATIONS

OUTPUT SIGNALS

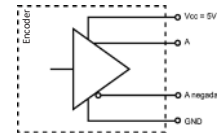
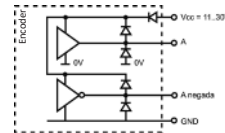
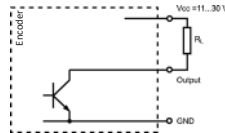

OUTPUT CIRCUIT	NPN Open Collector	Push-Pull Differential	RS422 (TTL compatible)
Reference code	0	1	2
Power supply	11...30 VDC	11...30 VDC	5 VDC ±5%
Output voltage	11...30 VDC	11...30 VDC	5 VDC
Consumption	40 mA	Typical: 45 mA Max: 150 mA	Typical: 70 mA Max: 150 mA
Max. load capability / channel	40 mA	±30 mA	±20 mA
Length of cable allowed	50 m (24 VDC)	100 m	1200 m
"Low" signal level	VOL < 0.4 VDC (24 VDC)	VOL < 2.5 VDC	VOL < 0.5 VDC
"High" signal level	VOH > 22 VDC (24 VDC)	VOH > VCC – 3 VDC	VOH > 2.5 VDC
Frequency	100 kHz	200 kHz	300 kHz
Short circuit protection	Not permanent	Yes	Yes
Protection polarity inversion	Yes	Yes	No

Channel A leads (90° electric) channel B, view from the shaft, shaft rotating clockwise

CONNECTION



	Cable 5x0,14 95.0008051 (*)	Cable 8x0,14 95.0008052 (*)	Connector M12 8p CCW
GND	White	White	1
VCC	Brown	Brown	2
A	Green	Green	3
B	Yellow	Grey	4
~A		Yellow	5
~B		Pink	6
0 (reference)	Grey	Blue	7
~0	Grey	Red	8

(*) For lengths over 2 meters standard cable, we recommend the use of twisted pair cable 2x2x0,14+1x0,14 (95.0008002) or 3x2x0,14+2x0,34 (95.0008003). Request the final cable length required to avoid junctions.

SERIE 22

MINIATURE BLIND HOLLOW SHAFT INCREMENTAL ENCODER FOR INDUSTRIAL APPLICATIONS

ACCESSORIES EXAMPLES

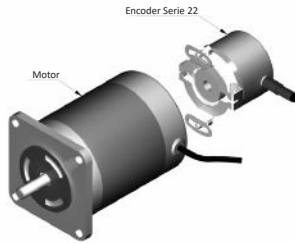

All the accessories available in the section "MOUNTING ACCESSORIES".

CONNECTION DIMENSIONS

Female connector not included

Connection 3

Radial M12 8p
male panel
counter clockwise

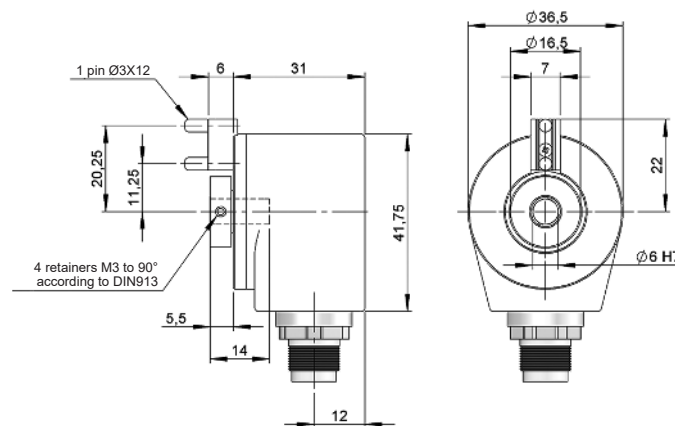

Female connector
95.0007152

